

---

# LINK

---

ANDREUCCI & HOISL DESIGN

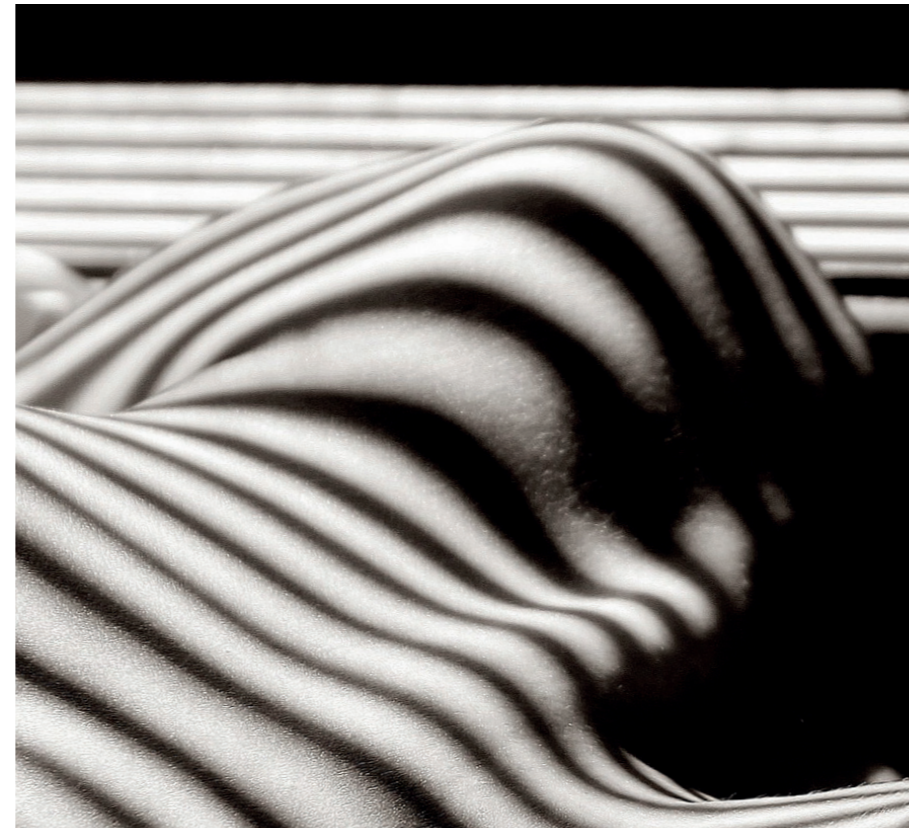

# LINK

“THE THREE OLDEST FORMS OF ART WERE  
ARCHITECTURE, COOKING AND CLOTHING.”

SAMUEL TAYLOR COLERIDGE

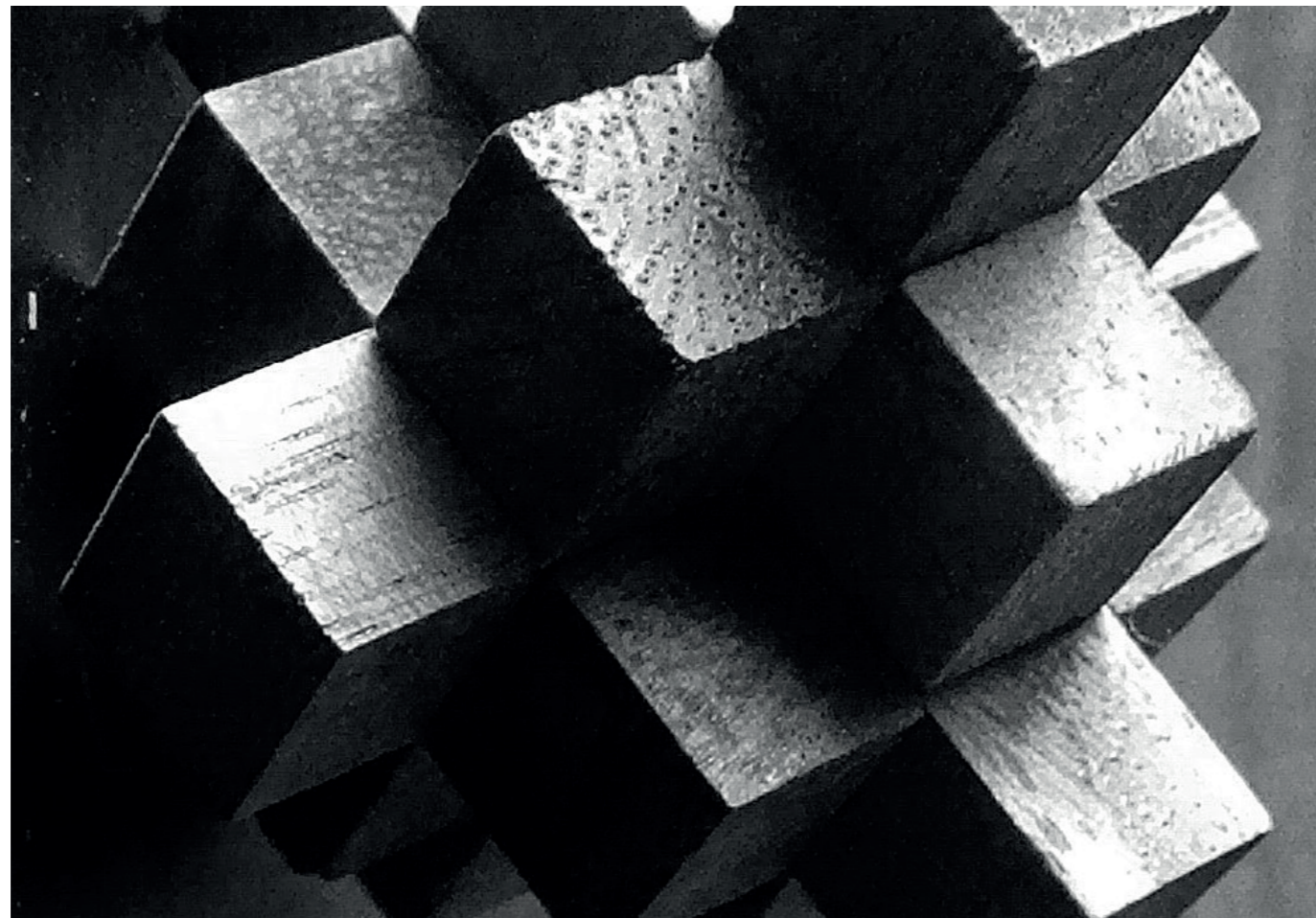



#LinkStories



LINK

ANDREUCCI & HOISL DESIGN

DEDICATED TO THOSE WHO FEEL READY TO REVOLUTIONIZE THE GENERAL IDEA OF DOMESTIC SPACE: IN SHORT, LINK MEANS CONNECTION. IT'S A SINGLE LINE, JOINING REAL SPACES AND EXPERIENCES. THERE ARE NO MORE SPACES DEDICATED TO JUST ONE ACTIVITY AS EVERYTHING IS INTERTWINED WHILE CELEBRATING THE UNIQUENESS OF THE PROJECT.





## ANDREUCCI & HOISL DESIGN

---

“THE IDEA OF A PROJECT COMES FROM THE SEARCH FOR A FUNCTIONAL APPROACH TO SPACE. WE FOCUS ON THIS SPACE IN ORDER TO PROVIDE IT WITH FUNCTIONALITY EITHER WHEN USING IT OR BEFORE AND AFTER; WE CREATE THUS AN EFFECTIVE AND PLEASANT SPACE IN EACH MOMENT OF LIFE.”

ANDREUCCI & HOISL

[WWW.SNAIDERO.COM](http://WWW.SNAIDERO.COM)



## ANDREUCCI & HOISL DESIGN

A FORWARD-LOOKING COLLABORATION

THE COLLABORATION WITH ANDREUCCI & HOISL STARTED IN 2016 WITH THE PROJECT "PASSEPARTOUT". THE PURPOSE: REVOLUTIONIZE FROM THE INSIDE. THE PROJECT FOLLOWS A SUBTLE, DEEP AND COMPLETE LOGIC. THEIR SIGHTS WERE SET ON DEVELOPING AN OPEN AND FLEXIBLE SYSTEM BASED ON CONTAINERS AND KITCHENWARE, DIFFERING FROM A DESIGN AND MATERIAL POINT OF VIEW AND LENDING THEMSELVES TO A WIDE RANGE OF PURPOSES. THE RESULT? A SYSTEM WHICH TOTALLY REDEFINES KITCHEN LIFE WITH A SERIES OF NEW FUNCTIONS AND UNEXPECTED TWISTS.

[WWW.SNAIDERO.COM](http://WWW.SNAIDERO.COM)



## SNAIDERO **STYLES**

---

## SNAIDERO **STYLES**

---

*"DESIGN CREATES CULTURE. CULTURE SHAPES VALUES. VALUES DETERMINE THE FUTURE."*  
ROBERT L. PETERS

### STYLE

"STYLE IS SUPERIOR TO TRUTH, IT CARRIES WITHIN IT  
THE PROOF OF ITS OWN EXISTENCE"

GOTTFRIED BENN

"STYLE IS IMPORTANT. MANY PEOPLE SCREAM THE TRUTH BUT  
WITHOUT STYLE IT IS HELPLESS".

CHARLES BUKOWSKI

THE KITCHEN FURNITURE COMBINES STYLE, FUNCTIONALITY AND  
PERSONALITY.

KNOWING THE DIFFERENT SNAIDERO FURNISHING STYLES CAN BE  
VERY HELPFUL IN EXPRESSING YOUR OPTIONS AT THE BEST AND  
CHOOSING AMONG THE SEVERAL DECORATION ALTERNATIVES.  
THE REALLY FUNNY THING IS TO TRY OUT AND MIX!

HERE'S OUR STYLE PROPOSAL:

ICONS, GLAM, CLASSIC, MINIMAL, INDUSTRIAL, URBAN.

---

---

LINK

ANDREUCCI & HOISL DESIGN

STYLE

MINIMAL

---

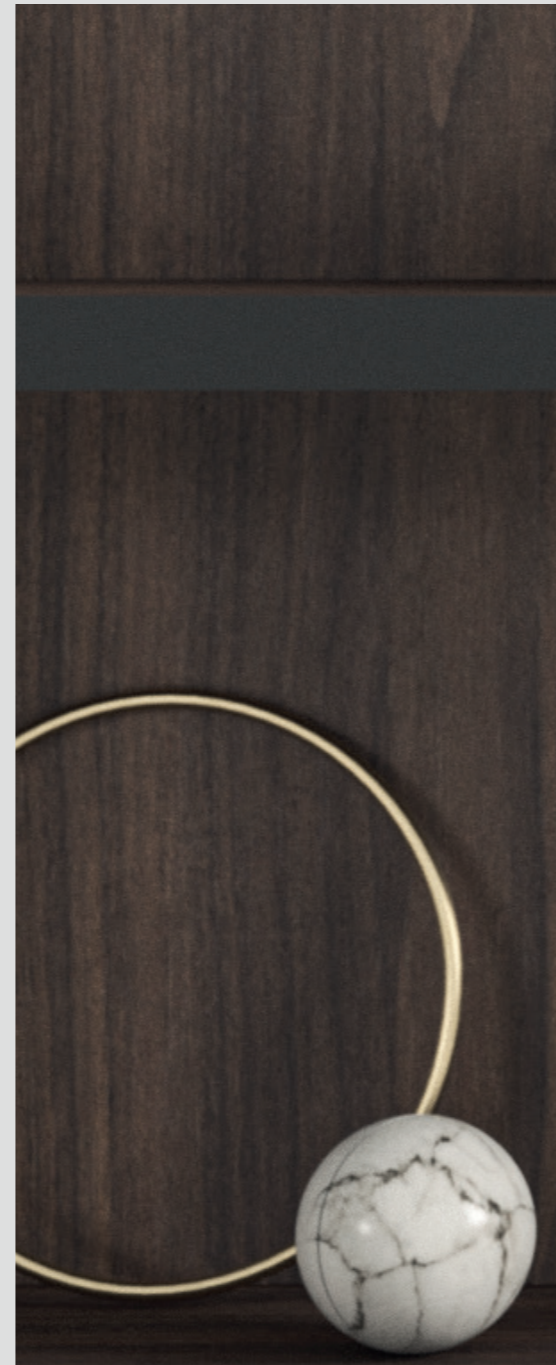

“Perfection is achieved not when there  
is nothing more to add, but when  
there is nothing else to take away”

*Antoine De Saint-Exupéry*

---

LINK

ANDREUCCI & HOISL DESIGN



STYLE

# MINIMAL

Minimalism is a concept even before a style!

MINIMALISM EMERGED IN THE 1960S AND REFLECTS THE RADICAL SHIFT OF THE ARTISTIC SCENE OF THAT PERIOD. THE ART MOVEMENT FROM THAT TIME WAS MARKED BY A REALITY REDUCTION, A LACK OF EXPRESSIVENESS AND AN EMOTIONAL COLDNESS OF ARTWORKS. THE TERM MINIMAL OR MINIMALISM WAS COINED IN 1965 BY THE ENGLISH PHILOSOPHER RICHARD WOLLHEIM IN AN ESSAY DESCRIBING THE ART CONTENT OF ESSENTIAL TRENDS OF THAT TIME. THIS PHILOSOPHICAL CHANGE RAPIDLY SPREAD ACROSS ALL THE CREATIVE DISCIPLINES INCLUDING FASHION, DESIGN AND ARCHITECTURE.

MINIMAL STYLE IS OFTEN EXPLAINED WITH THE FAMOUS MOTTO "LESS IS MORE", ADOPTED BY THE ARCHITECT MIES VAN DER ROHE. IN HIS PROGRAMME, HE EXPLAINS THAT MINIMALISM IS TO STRIP EVERYTHING DOWN TO ITS ESSENTIAL QUALITY AND HAVE ALL ITEMS REDUCED TO THE VERY BASIC AND STRICTLY NECESSARY ELEMENTS YET KEEPING PACE WITH MODERNITY. THIS IS EXACTLY THE REASON WHY MINIMALISM HAS TAKEN ON A VARIETY OF FORMS AND HAS LARGELY ADAPTED TO THE DIFFERENT STYLES WHICH HAVE EMERGED AND DEVELOPED OVER THE YEARS.







---

# LINK

ANDREUCCI & HOISL DESIGN

## PERFECT GEOMETRIC LINES

THE INTERACTION BETWEEN VOLUMES AND SURFACES REPRESENTS AN UNQUESTIONABLE DISTINGUISHING MARK OF LINK.

THE KITCHEN FEATURES AN INNOVATIVE DOUBLE SOLUTION FOR THE DOOR OPENING: THE ADOPTION OF EITHER A CURVED OR A FLAT CHANNEL ENSURES A HIGHLY AESTHETIC FUNCTIONALITY.

---



---

# LINK

“ARCHITECTURE IS THE LEARNED GAME,  
CORRECT AND MAGNIFICENT,  
OF FORMS ASSEMBLED IN THE LIGHT.”

LE CORBUSIER





---

## LINK

ANDREUCCI & HOISL DESIGN

### MONOLITH EFFECT

THE WORKTOP SURFACE CAN BE PERSONALIZED BY CHOOSING THE SAME FINISH AS THE FRONTS, TURNING THE LAY-OUT INTO A SEAMLESS WHOLE. THE PURE AESTHETICS OF THE MONOLITH EFFECT ENHANCES THE CLEAN GEOMETRIC LINES, MAKING THE SPACE A PROTAGONIST IN A SEQUENCE OF SOLIDS AND VOIDS.

■ Kitchen Link integrating SYSTEM



**SYSTEM S** RESTING ON THE OPERATIVE TOP AND INTEGRATED NEXT TO THE TALL UNITS' AREA.

**SYSTEM M** RESTING ON THE ISLAND.

**SYSTEM L** RESTING ON THE OPERATIVE TOP.

e\_wall finishes: **/SYSTEM S:** STRUCTURE IN CANADA WALNUT MELAMINE; **Drop-down doors:** PURE BLACK MATT LACQUER; **Back panels on sink area:** LIT MAGNETIC GLASS; **/SYSTEM M:** STRUCTURE IN CANADA WALNUT MELAMINE; **Back panels:** AT 44 CM FIX HEIGHT IN FUMÉ GLASS; **/SYSTEM L:** STRUCTURE IN CANADA WALNUT MELAMINE; **Wall units:** PURE BLACK MATT LACQUER.

WWW.SNAIDERO.COM



Finishes: **/Doors and Tops:** PIETRA SERENA MELAMINE; **/Snack Top:** CANADA WALNUT LAMINATE; **/Handle-profile:** BLACK KNURLED ALUMINUM; **/Channel:** BLACK ANODIZED ALUMINUM.



SENSORY RESEARCH



---

---





---

# LINK

“IT IS A FUNNY PARADOX OF DESIGN: UTILITY  
BREEDS BEAUTY.  
THERE IS ELEGANCE IN EFFICIENCY”.

BEN ORLIN

---



---

## LINK

ANDREUCCI & HOISL DESIGN

### PEOPLE AT THE CENTER

THE PROJECT CONVEYS THE CONNECTION BETWEEN THE SPACES: THE MOMENTS WHEN PEOPLE'S EXPERIENCES ARE THE CENTER AND THE INTERACTION THAT OCCURS BETWEEN THE KITCHEN AND ITS USE, CREATING A VERY EFFECTIVE CONTEXT WHICH CAN BE ENJOYED AT ANY TIME OF THE DAY.



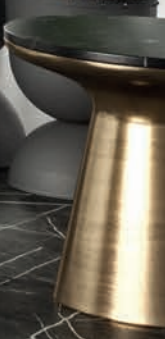

SENSORY RESEARCH



---

## LINK

ANDREUCCI & HOISL DESIGN

Finishes: /Doors: NORDIC WHITE MICALISED LACQUER; /Worktop: K-SOUL MATT QUARTZ; /Snack Top: COFFEE ELM WOOD; /Back panel: IN LIT MAGNETIC GLASS; /Handle-profile: TITANIUM-FINISH KNURLED ALUMINUM; /Channel: TITANIUM-FINISH ALUMINUM.

■ Kitchen Link integrating **SYSTEM e-Wall**  
ERGONOMIC  
System S INTEGRATED ON THE OPERATIVE WORKTOP;  
System M RESTING ON THE ISLAND;  
System L RESTING ON THE OPERATIVE TOP AND  
INTEGRATED BETWEEN THE TALL UNITS.

e\_wall finishes: /SYSTEM S: STRUCTURE IN COFFEE ELM WOOD; Drop-down doors: PURE BLACK MATT LACQUER;  
Back panel to sink area: LIT AND MAGNETIC GLASS;  
/SYSTEM M: STRUCTURE IN COFFEE ELM WOOD;  
Back panels: AT 44 CM FIX HEIGHT IN FUMÉ GLASS FINISH;  
/SYSTEM L: STRUCTURE AND WALL UNITS IN COFFEE ELM WOOD.

WWW.SNAIDERO.COM



---

# LINK

ANDREUCCI & HOISL DESIGN

---





---

# LINK

“YOU CANNOT THINK OF AN ARCHITECTURE  
WITHOUT THINKING OF PEOPLE”.

RICHARD ROGERS



---

## LINK

ANDREUCCI & HOISL DESIGN

### CONNECTION

SIMPLE LINES. SQUARE SHAPES. IMPACTFUL  
PROFILES. AMAZING EYE-CATCHER.  
LINK TURNS INTO THE TRIUMPH OF GEOMETRIC  
LINES IN A THREE-DIMENSIONAL PERFORMANCE  
OVERCOMING THE CONCEPT OF KITCHEN,  
WITHOUT COMPROMISING ON THE VALUE  
OF DOMESTIC AND FUNCTIONAL SPACE.







---

## LINK

ANDREUCCI & HOISL DESIGN

**Finishes/Doors:** TITANIUM MATT LACQUER AND PAULOWNIA GREY MELAMINE; **Worktops:** IN CERAMIC "CALCE TORTORA"; **Worktop:** MATT QUARTZ BLACK&MORE; **Handle-profile:** BLACK-FINISH KNURLED ALUMINUM; **Channel:** BISTROT GREY POWDER COATED ALUMINUM.

■ Kitchen Link integrating **SYSTEM e-Wall**  
ERGONOMIC

**System S** INTEGRATED NEXT TO THE OPERATIVE AREA;  
**System M** RESTING ON THE ISLAND;  
**System L** RESTING ON THE KITCHEN.

**e-wall finishes/SYSTEM S:** STRUCTURE IN PAULOWNIA GREY MELAMINE; **Drop-down doors:** PURE BLACK MATT LACQUER;  
**/SYSTEM M:** STRUCTURE IN PAULOWNIA GREY MELAMINE;  
**Back panels:** AT 44 CM FIX HEIGHT IN FUMÉ GLASS FINISH;  
**/SYSTEM L:** STRUCTURE IN PAULOWNIA GREY MELAMINE, WALL UNITS IN TITANIUM MATT LACQUER;  
**Back panels:** LIT AND MAGNETIC GLASS.

WWW.SNAIDERO.COM





---

# LINK

ANDREUCCI & HOISL DESIGN

STYLE

# GLAM

---

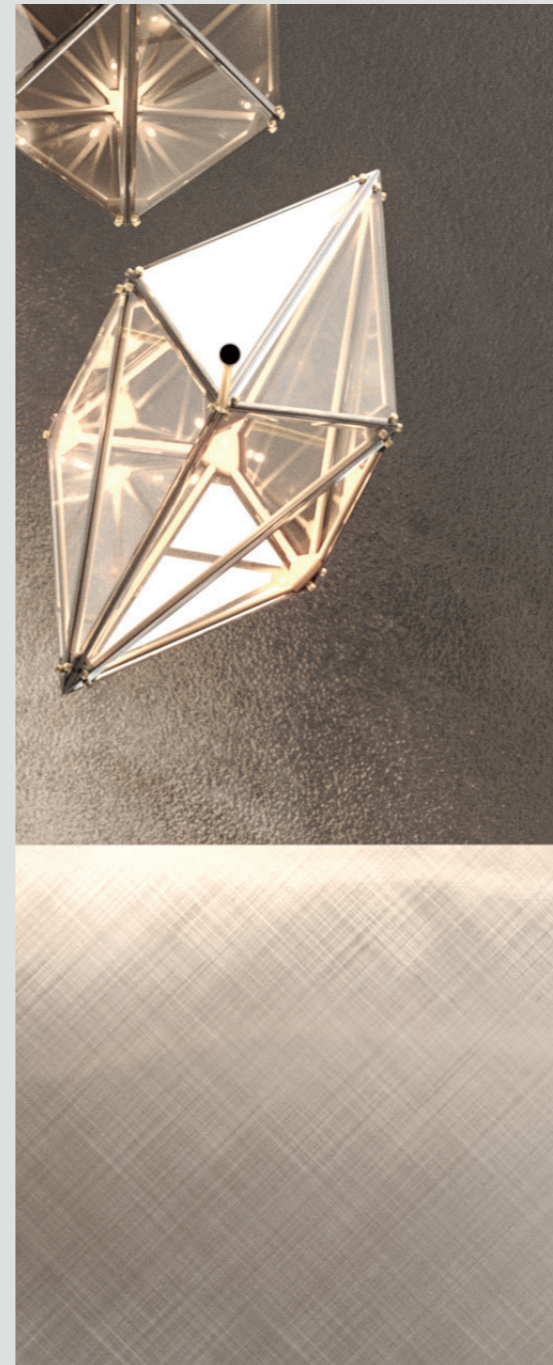
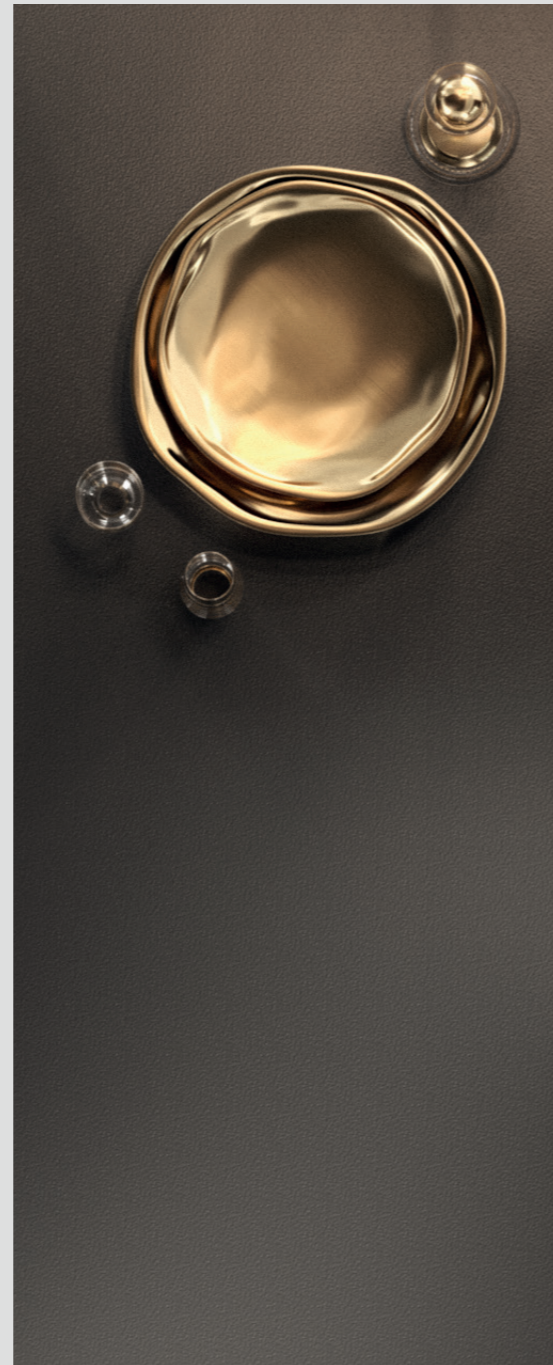

“Your home should tell the story of who you are,  
and be a collection of what you love”.

*Nate Berkus*

---

LINK

ANDREUCCI & HOISL DESIGN

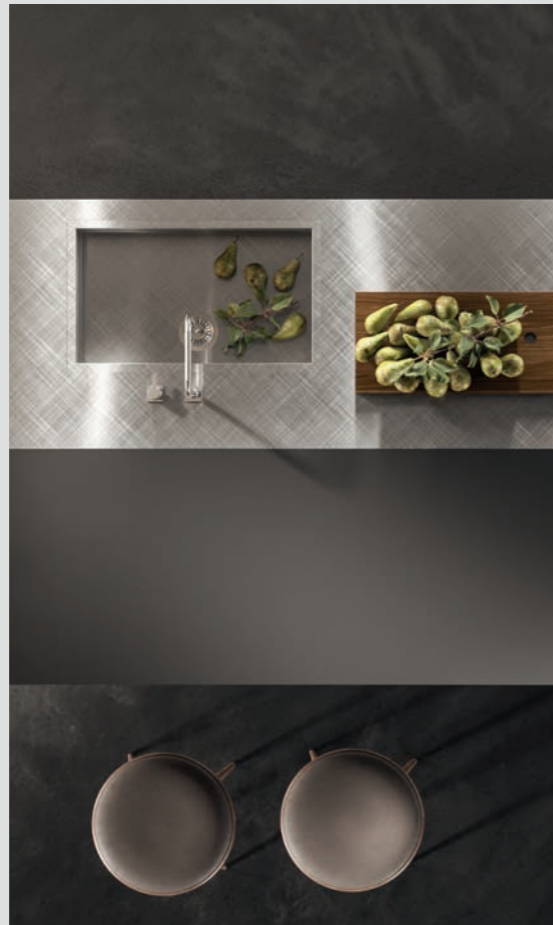

STYLE

# GLAM

---

Unquestionably sophisticated and brilliant, glam style makes your home even more beautiful, recalling the classic taste yet evoking a contemporary spirit.

CUSCIONS DECORATED WITH FEATHERS AND FRINGES, BOUCLÉ POUFS, MARBLE AND GOLD METAL TEA TABLES, UNIQUE MODERN LAMPS CREATING A LUXURY AND CLASSY AMBIANCE.

GLAM RULE IS THAT STRIKING AND DRAMATIC MATERIALS ARE USED TO DECORATE WITH STYLE AND VANITY. THE AMBIANCE AND THE FURNITURE NEED TO CONVEY AN UNCONVENTIONAL ELEGANCE BY SELECTING COLLECTOR'S PIECES.

GLAM DECOR ESSENTIALS INCLUDE: MIRRORS, GOLDEN OR SILVER FRAME AND ANY REFLECTIVE SURFACE PROVIDING A LUXURIOUS AND OPULENT LOOK.

WHICH ARE THE MAIN COLORS OF A GLAM HOUSE? FOR A PERFECT GLAM TOUCH, BEIGE TONALITY CANNOT MISS IN YOUR HOME.

THIS IS ACTUALLY THE MAIN SHADE, FOLLOWED BY BLACK, GREY, CREAM, PURPLE, POWDER, TURQUOISE, OIL BLUE, LILAC AND SAND.

IF YOU WANT TO TURN YOUR ROOM INTO A BRIGHTER AND LIGHTER SPACE, YOU NEED TO PLAY WITH SHADES AND ADD SILVER OR GOLDEN DETAILS: THEY WILL ADD A TOUCH OF GLAM AND WARM UP THE AMBIANCE WHICH WILL SHINE LIKE A GEM.

VELVET, BESIDES BEING AN INCREDIBLY RESISTANT MATERIAL, IS UNQUESTIONABLY THE TRUE PROTAGONIST OF GLAM STLYE FABRICS AND COVERINGS: IT ENHANCES ANY SEAT OR DECORATIVE ITEM SUCH AS RUGS OR BOUCLÉ' POUFS BY ADDING A TOUCH OF CHARACTER AND GENTLE BRIGHTNESS.

CEILING LAMPS AND LIGHTS ARE ANOTHER REMARKABLE ELEMENT WHEN YOU WANT TO CONVEY A STYLISH LOOK TO THE AMBIANCE.

RUGS PLAY AN IMPORTANT ROLE AS WELL, PROVIDED THAT THEY ARE SHOWY AND SOFT.

TO DECORATE WITH STYLE AND VANITY, FURNITURE MUST CONVEY ELEGANCE AND ORIGINALITY, PICKING COLLECTOR'S ITEMS AND UNIQUE PIECES IN EITHER DARK OR NEUTRAL WOOD, CRYSTAL, ROUND SHAPES GLOSSY REFLECTIONS, REFINED CHANDELSTICKS, OVAL DINING TABLES AND WALL PAPER IN GLOW EFFECT.





---

# LINK

“OUR JOB IS TO GIVE A CLIENT  
NOT WHAT HE WANTS BUT WHAT HE NEVER  
DREAMED THAT HE WANTED”.

DENYS LADSUN



---

## LINK

ANDREUCCI & HOISL DESIGN

### MORE THAN MINIMAL

DEFINITELY MINIMAL, LINK IS ABLE TO SUIT ALL TASTES AND STYLES THANKS TO THE LARGE NUMBER OF AVAILABLE MATERIALS: FROM THE TRADITIONAL TO THE MOST GLAMOROUS ONES. EXTREMELY CONTEMPORARY STYLE COMBINED WITH A PERSONAL USER'S TOUCH.

**Finishes/Doors:** CHAMPAGNE MICALISED LACQUER; **/Wall units and Tall units:** HIGH-GLOSS FUMÉ EUCALYPTUS; **/Worktops:** STAINLESS STEEL CROSS HAIRLINE FINISH BARAZZA; **/Snack top:** MATT QUARTZ BLACK&MORE; **/Handle-profile:** BLACK-FINISH KNURLED ALUMINUM; **/Flat-channel:** BLACK ANODIZED ALUMINUM.

■ Kitchen Link integrating **SYSTEM e-Wall**  
ERGONOMIC

**SYSTEM M** INTEGRATED ON THE ISLAND AND ON THE KITCHEN.

**e\_wall finishes;/SYSTEM M island:** STRUCTURE DEEP 22 CM IN ASH NOIR WOOD WITH LED LIGHT VERTICALLY INTEGRATED AT THE CENTER OF THE SIDE PANEL; **Back panels:** AT 44 CM FIX HEIGHT IN FUMÉ GLASS FINISH; **/SYSTEM M kitchen:** STRUCTURE DEEP 22 CM IN ASH NOIR WOOD WITH LIT AND MAGNETIC BACK PANEL; **Back panels:** LIT AND MAGNETIC GLASS.

[WWW.SNAIDERO.COM](http://WWW.SNAIDERO.COM)





---

# LINK

ANDREUCCI & HOISL DESIGN

## SEAMLESS DESIGN

THE AVANT-GARDE CHARACTER OF LINK LIES NOT JUST IN ITS SHAPES, BUT ALSO IN THE CHOICE OF MATERIALS: AN EXAMPLE OF THIS IS THE CONTINUOUS WOOD GRAIN FROM DOOR TO DOOR DESIGNING AN INTERESTING BOOK-MATCHING EFFECT.





SENSORY RESEARCH

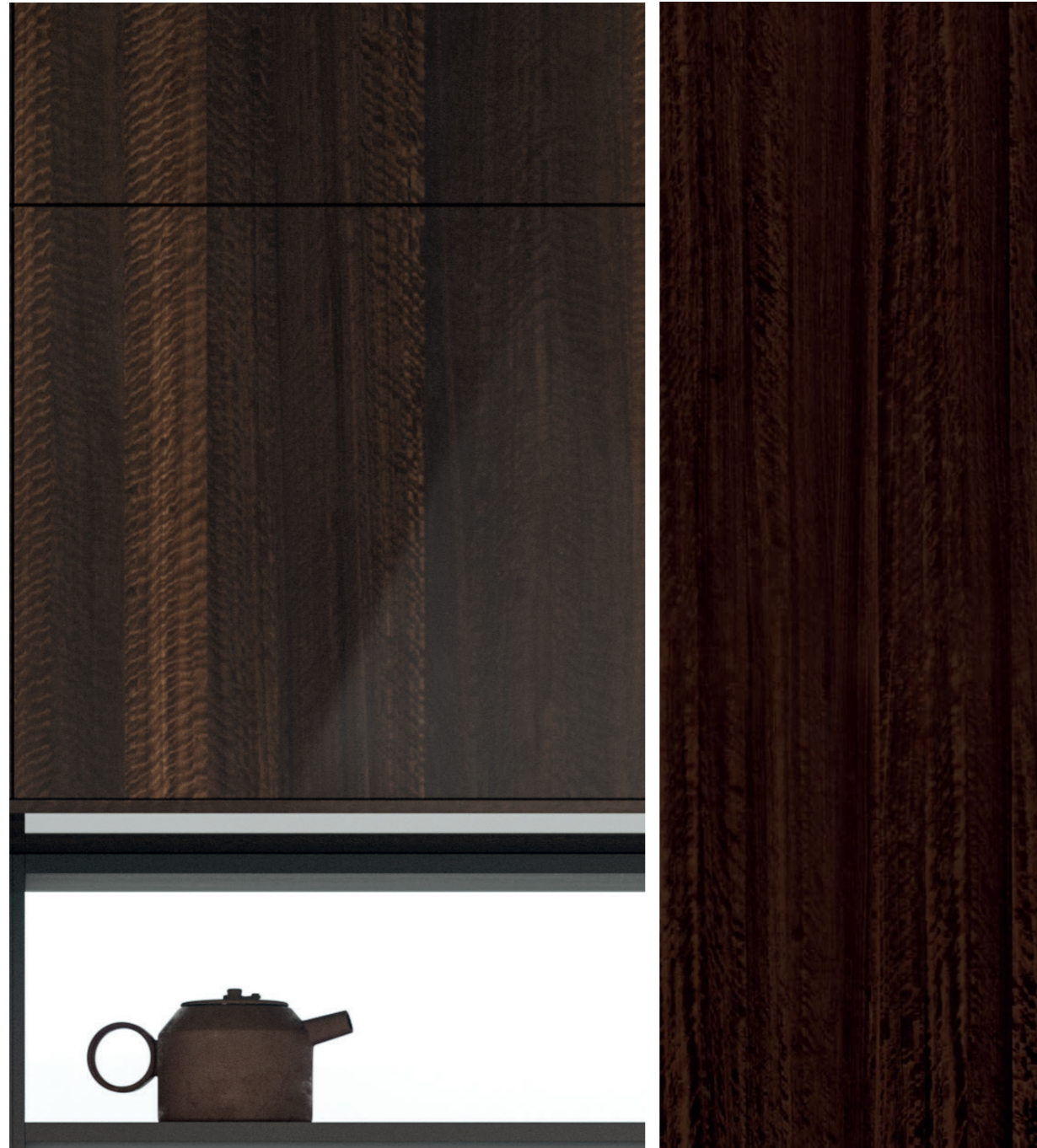

---

## LINK

ANDREUCCI & HOISL DESIGN

OPENING DOWN THE FULL TALL CABINET'S HEIGHT  
AS THE CHANNEL SYSTEM IS AVAILABLE ALSO  
FOR THE ARRANGEMENTS OF TALL CABINETS,  
THE CLEAN LINE CAN REACH THE FLOOR LEVEL,  
THUS PROVIDING A HIGH AESTHETIC QUALITY  
AND A CONTINUATION OF THE HANDLELESS DESIGN.







---

## LINK

ANDREUCCI & HOISL DESIGN



STYLE

# URBAN



“At times all I need is a brief glimpse, an opening in the midst of an incongruous landscape, a glint of light in the fog, the dialogue of two passersby meeting in the crowd, and I think that, setting out from there, I will put together, piece by piece, the perfect city, made of fragments mixed with the rest, of instants separated by intervals, of signals one sends out, not knowing who receives them”.

*Italo Calvino*

---

LINK

ANDREUCCI & HOISL DESIGN



STYLE

# URBAN

The Urban style is characterized by its intense connections with contemporary arrangements; inspired by metropolitan atmospheres, it takes arguments from the life style in the big cities.

THE EXCHANGE BETWEEN ANTIQUE AND MODERN ELEMENTS IS HIGHLY VALORIZED.

THE URBAN ENVIRONMENT FEATURES BRICKS, EXPOSED PIPING AND BEAMS, WARM-TONED TILES. WIDE AND MODERN WINDOWS CAN ALSO BE PERSONALIZED WITH VINTAGE ELEMENTS.

THE DETAILS AND THE WARM TONES OF WOOD ON FLOORING TURN THE ENVIRONMENT INTO A COZY AND PLEASANT SPACE.





---

# LINK

“THE SOUL NEVER THINKS WITHOUT A PICTURE”

ARISTOTELE

---

---

## LINK

ANDREUCCI & HOISL DESIGN

### USEFUL IS BEAUTIFUL

FUNCTIONALITY FINALLY GIVES A MEANING TO AESTHETICS. LINK PROMOTES FUNCTION THROUGH ITS MINIMAL AND INNOVATIVE DESIGN. THE PROJECT REALIZES THE CONNECTION BETWEEN THE SPACES, GIVING PEOPLE'S EXPERIENCE THE CENTRAL PLACE.





SENSORY RESEARCH

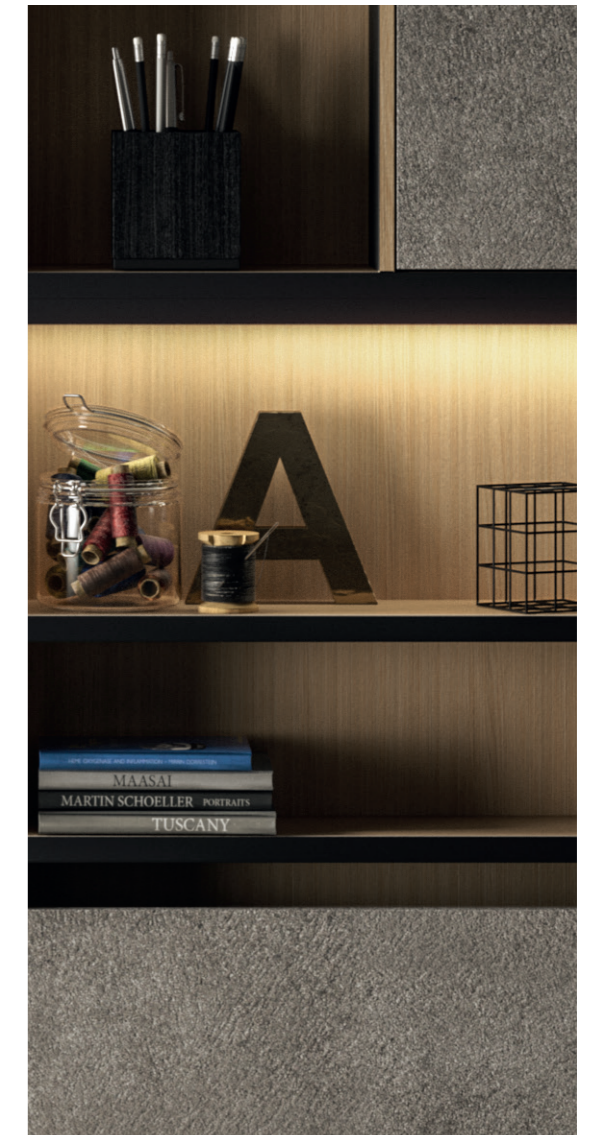

---



---

## LINK

ANDREUCCI & HOISL DESIGN

Finishes: /Doors: ULTRA BLACK MATT LACQUER WITH EDGE; /Wall units: ARENARIA GREY MELAMINE; /Top: ULTRA BLACK MATT LAMINATE; /Handle-profile: BLACK KNURLED ALUMINUM; /Flat-channel: BLACK ANODIZED ALUMINUM.

■ Link kitchen integrating **SYSTEM e-Wall**  
Ergonomic

**SYSTEM M** RESTING ON THE ISLAND FUNCTIONAL AREA;  
**SYSTEM L** INTEGRATED ABOVE THE KITCHEN WORKTOP.

Finishes **SYSTEM e-wall**; /**SYSTEM L**: STRUCTURE IN SILVER MELAMINE AND WALL UNITS IN ARENARIA GREY MELAMINE; **Back panels**: BACK-LIT AND MAGNETIC. **SYSTEM M**: STRUCTURE IN COPENAGHEN OAK MELAMINE; /Horizontal sections featuring **black ABS edge**; /**Bottom panel**: SPECIFIC BASE CABINET TO INTEGRATE ST. STEEL CHANNEL BY BARAZZA THE STRUCTURES' BOTTOM PANEL CAN INTEGRATE THE EQUIPPED CHANNELS BY BARAZZA ON 90 CM WIDTH.

---







---

# LINK

ANDREUCCI & HOISL DESIGN

Kitchen Link integrating **SYSTEM e-Wall**  
ERGONOMIC  
**SYSTEM L** RESTING ON THE OPERATIVE TOP.

Finishes **SYSTEM e-wall**/ **SYSTEM L**: STRUCTURE  
IN SILVER MELAMINE AND WALL UNITS IN ARENARIA  
GREY MELAMINE; **Back panels**: BACK-LIT AND MAGNETIC.

---



---

# LINK

ANDREUCCI & HOISL DESIGN

■ Kitchen Link integrating SYSTEM **e-Wall**  
ERGONOMIC  
SYSTEM **M** RESTING ON THE ISLAND OPERATIVE TOP.

Finishes SYSTEM e\_wall: SYSTEM **M**: STRUCTURE IN COPENAGHEN OAK MELAMINE; /Horizontal sections featuring: BLACK ABS EDGE; /Bottom Panel: SPECIFIC BASE UNIT W.90 CM FOR THE INTEGRATION OF STAINLESS STEEL EQUIPPED CHANNELS BY BARAZZA.

---





---

# LINK

“I THINK THAT PEOPLE WANT TO FEEL GOOD IN A SPACE.  
ON THE ONE HAND IT’S ABOUT SHELTER,  
BUT IT’S ALSO ABOUT PLEASURE”.

ZAHA HADID





---

## LINK

ANDREUCCI & HOISL DESIGN

**A STYLISH TOUCH FOR DIFFERENT ENVIRONMENTS**  
LINK AIMS TO PROVIDE AN ANSWER TO BOTH AESTHETIC AND FUNCTIONAL REQUIREMENTS. THE GREAT VERSATILITY OF THE PROJECT ALLOWS TO CREATE TASTEFUL SOLUTIONS EVEN IN SMALL CONTEXTS.

**Finishes:**/Doors: PAPER WHITE MATT LACQUER;/Wall units: SUGI BAN MELAMINE;/Worktop: SILVER LAMINATE;/Handle-profile: BLACK KNURLED ALUMINUM;/Flat-Channel: BLACK ANODIZED ALUMINUM.

■ Kitchen Link integrating **SYSTEM e-Wall**  
ERGONOMIC

**SYSTEM S** INTEGRATED IN THE OPERATIVE AREA.  
**SYSTEM L** INTEGRATED IN THE OPERATIVE AREA.

**SYSTEM e-wall finishes:**/ **SYSTEM L:** STRUCTURE IN SILVER MELAMINE AND WALL UNITS IN SUGI BAN MELAMINE; **Drop-down doors:** SILVER MELAMINE; **SYSTEM S:** STRUCTURE IN SILVER; **Back panels:** LIT AND MAGNETIC.

---

[WWW.SNAIDERO.COM](http://WWW.SNAIDERO.COM)







---

# LINK

ANDREUCCI & HOISL DESIGN

Kitchen Link integrating SYSTEM **e-Wall**  
ERGONOMIC  
SYSTEM S INTEGRATED IN THE OPERATIVE AREA.

Finishes SYSTEM e\_wall/ SYSTEM S: STRUCTURE IN  
SILVER MELAMINE. Back panels: BACK-LIT AND MAGNETIC.

---



---

# LINK

ANDREUCCI & HOISL DESIGN

Kitchen Link integrating SYSTEM **e-Wall**  
ERGONOMIC  
SYSTEM **L** INTEGRATED IN THE OPERATIVE AREA.

Finishes SYSTEM e\_wall;/ SYSTEM **L**: STRUCTURE IN  
SILVER MELAMINE AND WALL UNITS IN SUGI BAN MELAMINE.

---



---

# LINK

ANDREUCCI & HOISL DESIGN

Kitchen Link integrating SYSTEM **e-Wall**  
ERGONOMIC  
SYSTEM **L** INTEGRATED IN THE OPERATIVE AREA.

**SYSTEM L**  
IS AVAILABLE WITH VERTICAL LIFT OPENING DOOR, MANUALLY OPERATED (AUTOMATIC OPTION IS AVAILABLE ON REQUEST). THE OPEN AND FUNCTIONAL SETTING TURNS INTO A CLOSED ARRANGEMENT REVEALING AN UPPER OPEN UNIT. A SIMPLE ACTION TAKES A WORKING AREA TO A WELCOMING AND RELAX SPACE, AS THE BEST LIVING.

---



# Opening systems

THE MOST CONTEMPORARY KITCHENS FEATURE A CHANNEL-OPENING, AN INNOVATIVE SOLUTION CONCEIVED TO PROVIDE A MINIMALIST LOOK TO THE FURNITURE STYLE: CLEAN AND ESSENTIAL LINES WITHOUT HOWEVER COMPROMISING ON THE FUNCTIONALITY OF THE SELECTED KITCHEN.

KITCHEN MODEL LINK OFFERS TWO OPENING SYSTEMS: WITH "C" SHAPED CURVED CHANNEL AND WITH FLAT-CHANNEL PROFILE. BOTH SYSTEMS ENHANCE THE SURFACE FINISHES WHICH, WITHOUT ANY VISUAL BREAK, VARY THE CABINETS' OPENING ASPECT AND CREATE DISTINGUISHED AND FUNCTIONAL UNITS WHILE IMPROVING THE CLEANING OPERATIONS AS COMPARED TO A TRADITIONAL HANDLE.

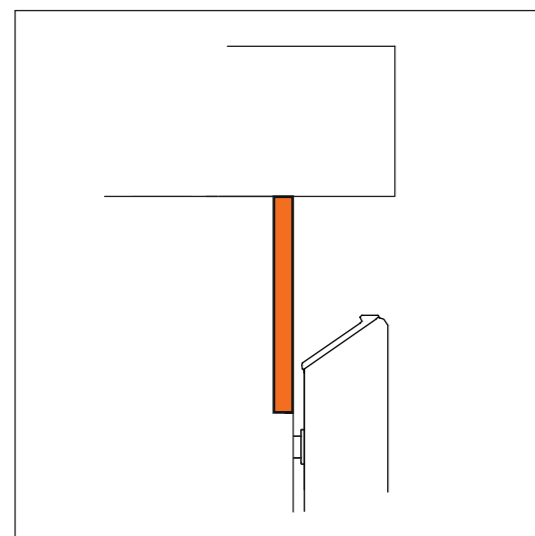

**OPENING SYSTEM**  
FLAT CHANNEL

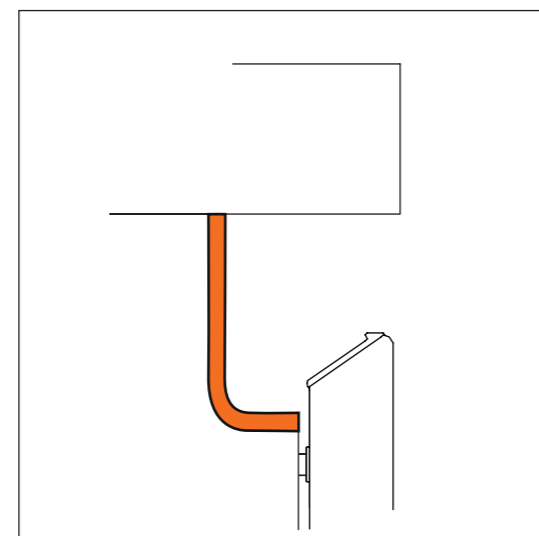

**OPENING SYSTEM**  
CHANNEL





#LinkStories



# LINK

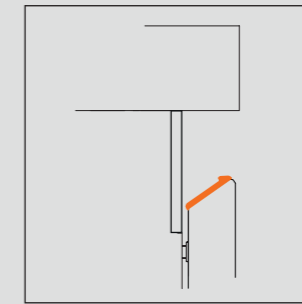

## OPENING SYSTEM

### FLAT CHANNEL

THE DOOR FEATURES A 35-DEGREE SLANTED INTEGRATED PROFILE, MADE IN KNURLED ALUMINUM, AVAILABLE IN THREE FINISHES: STAINLESS STEEL, TITANIUM, BLACK.

THE SPECIFIC PROFILE-KNURLING IMPROVES THE DOOR OPENING.

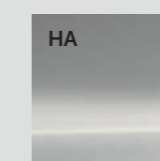

ST.STEEL

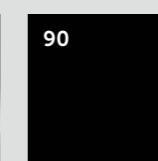

BLACK

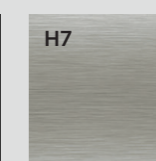

TITANIUM





OPENING SYSTEM

---

FLAT CHANNEL



#LinkStories

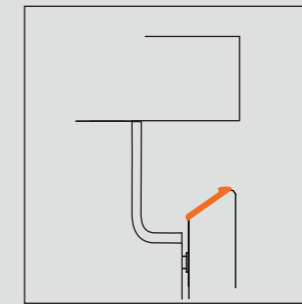

## OPENING SYSTEM

### CHANNEL

THE CHANNEL SOLUTION PROVIDES A CLEAN AESTHETIC AND A COMFORTABLE DOOR OPENING.

THE DOOR FEATURES A 35-DEGREE SLANTED INTEGRATED PROFILE, MADE IN KNURLED ALUMINUM, AVAILABLE IN THREE FINISHES: STAINLESS STEEL, TITANIUM, BLACK.

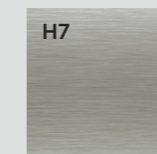

TITANIUM



BLACK

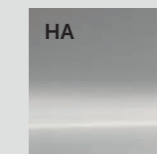

ST.STEEL





OPENING SYSTEM

---

CHANNEL

---

LINK

ANDREUCCI & HOISL DESIGN

SUPPORTING

STRUCTURE



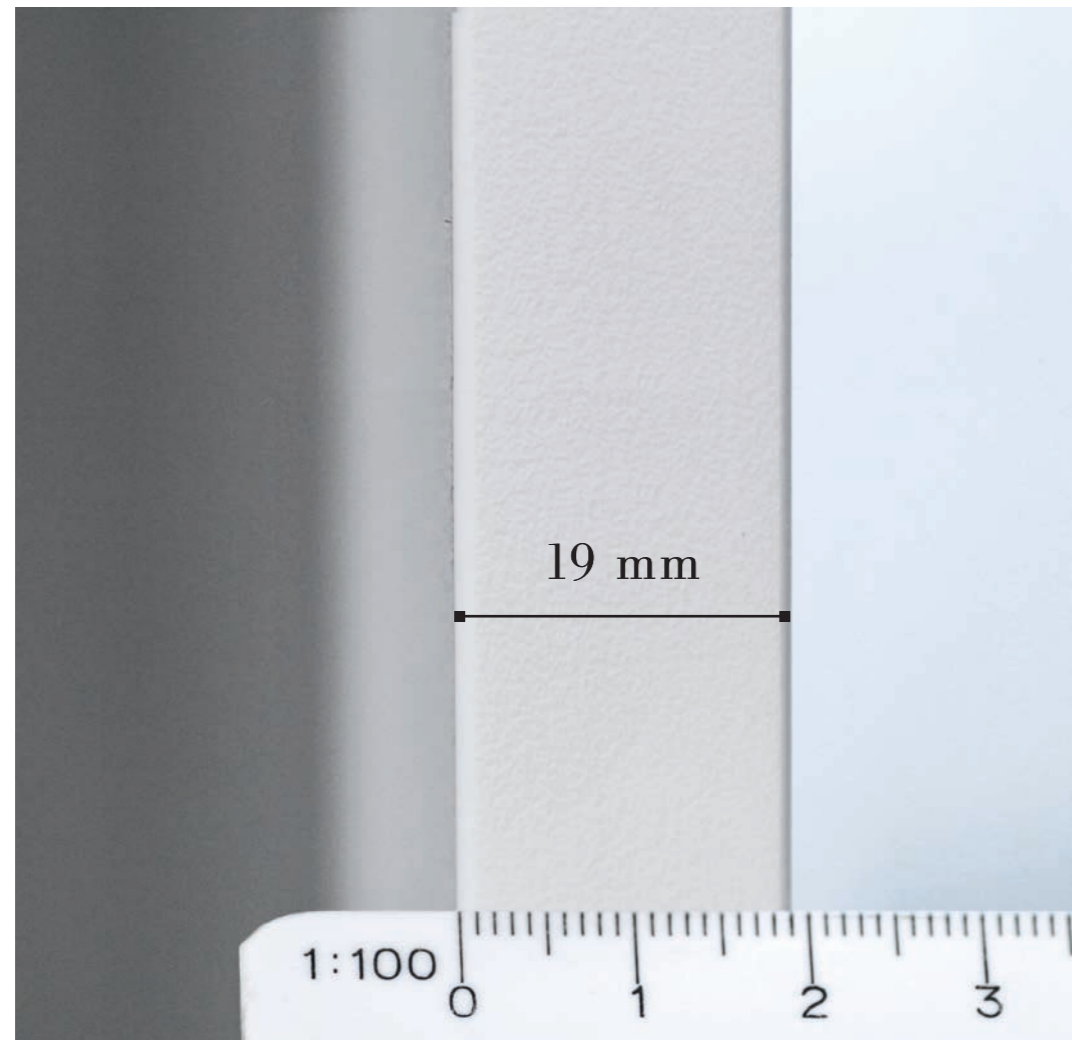

100% LOW EMISSION PANEL

## CABINETS' CARCASSES

### 19MM

THE CABINETS' CARCASSES ARE MADE OF 19 MM THICK PARTICLE BOARD PANELS, HAVING A VERY LOW FORMALDEHYDE EMISSION (LESS THAN HALF OF THE E1 CLASS). THE PANELS, COVERED WITH MELAMINE RESINS TO OBTAIN HIGH ABRASION RESISTANCE AND EASY TO CLEAN SURFACE, FEATURE A FRONT ABS THICK EDGE. THE CABINETS' BACK PANELS ARE MADE OF HDF (HIGH DENSITY FIBERBOARD). THE 19 MM THICK SHELVES ARE MADE OF THE SAME CARCASS MATERIAL AND ARE ADJUSTABLE TO DIFFERENT HEIGHT POSITIONS.

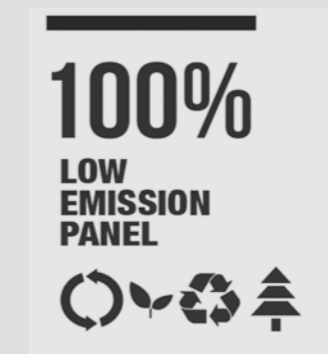

# MATERIALS CARCASS STRUCTURE

CARCASS: IGLOO WHITE

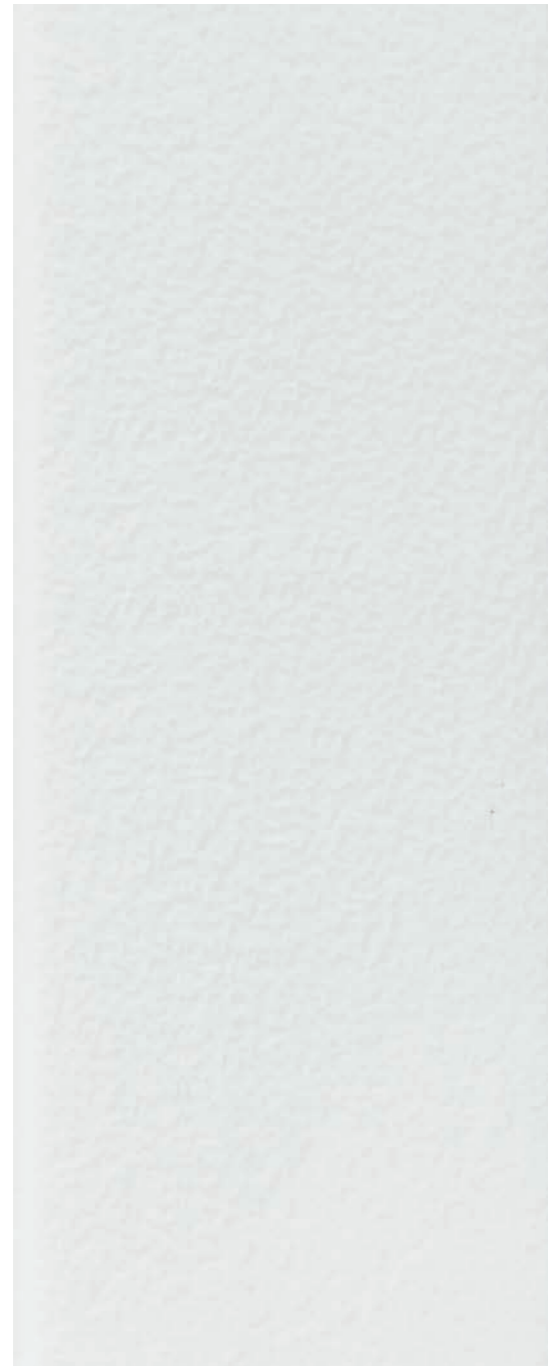

CARCASS: MONOLITH GREY

---

CARCASS: TEXTURE GREY



CARCASS: STATUS GREY

---

---

# LINK

ANDREUCCI & HOISL DESIGN

“THE DETAILS ARE NOT THE DETAILS.  
THEY MAKE THE DESIGN”.

CHARLES EAMES

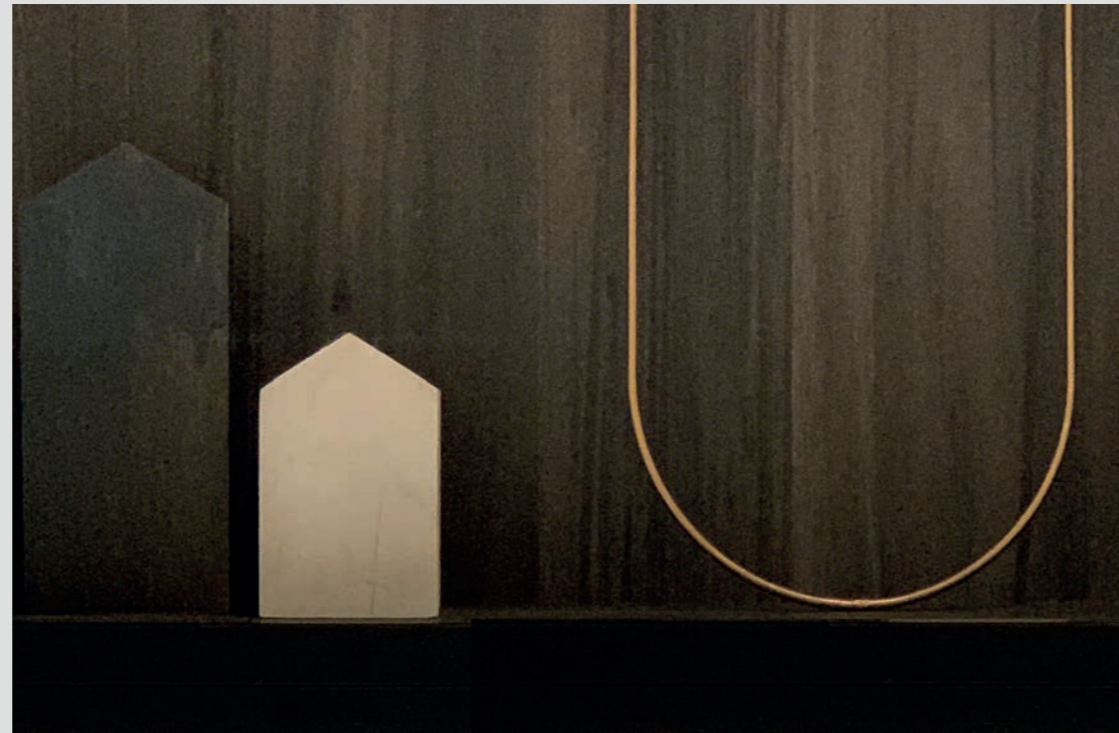

THE HIGHLY VERSATILE PROJECT OFFERS COUNTLESS CHROMATIC CUSTOMIZATIONS.

---

# LINK

ANDREUCCI & HOISL DESIGN



“DETAILS MAKE PERFECTION  
AND THE PERFECTION IS NOT A DETAIL”.

LEONARDO DA VINCI



THE INTELLIGENCE SEEN FROM THE INSIDE

## COLLECTION PASSEPARTOUT

THE PROJECT HAS BEEN DESIGNED EXCLUSIVELY FOR SNAIDERO BY TWO PRESTIGIOUS SIGNATURES: ALESSANDRO ANDREUCCI & CHRISTIAN HOISL. THEIR AMBITION WAS TO DEVELOP AN OPEN AND FLEXIBLE SYSTEM, BASED ON CONTAINERS AND TOOLS FEATURING DISTINCTIVE DESIGNS AND MATERIALS, WHICH CAN BE USED IN DIFFERENT WAYS. THE RESULT? A SYSTEM THAT CAN COMPLETELY REVOLUTIONISE LIFE IN THE KITCHEN, THANKS TO ITS NEW FUNCTIONS AND UNEXPECTED SOLUTIONS.



QUALITY  
CERTIFICATION

ISO 9001



ENVIRONMENTAL  
CERTIFICATION

ISO 14001



FSC®  
CERTIFICATION



The mark of  
responsible forestry  
FSC® C133440

CARB  
CERTIFICATION



Phase II the EPA's TSCA Title 6 and the  
CATAS Quality Award certification.

# FULL GREEN AHEAD!

FUTURE AND SUSTAINABILITY

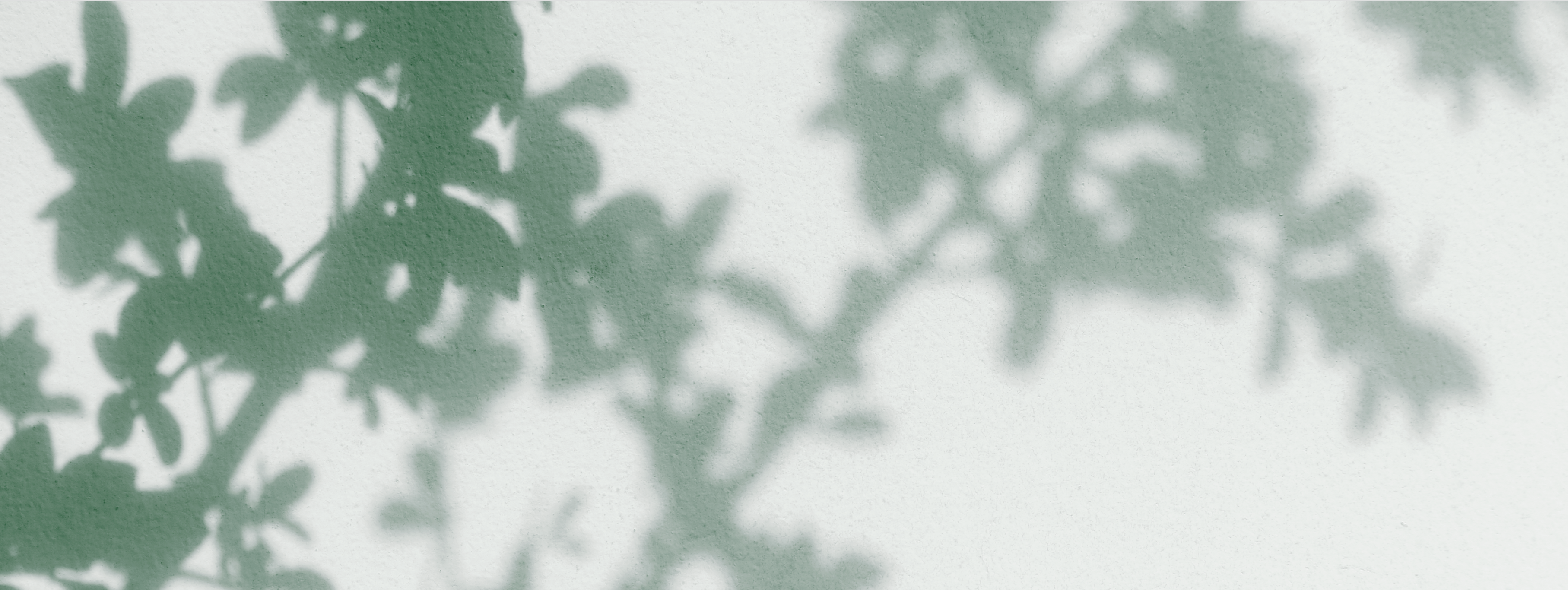

AIMING AT A SUSTAINABLE GROWTH. FOR US THIS IS AN OPPORTUNITY RATHER THAN AN IMPOSITION. IN OUR OWN SMALL WAY, WE SEEK THE OPPORTUNITY TO ENSURE THE NEEDS OF THE PRESENT WITHOUT COMPROMISING ON THE ABILITY FOR FUTURE GENERATIONS TO MEET THEIR OWN NEEDS. THIS IS WHY EVERY DAY WE STRIVE TO GO BEYOND STANDARDS. BEYOND CERTIFICATIONS, WHILE FOCUSING OUR DECISIONS ON IMPROVING DOMESTIC ENVIRONMENT.

“OUR SPECIALTY IS TO EXCLUSIVELY MANUFACTURE KITCHENS, GIVING ALL RESPECT TO PEOPLE AND TO THE ENVIRONMENT, BY USING THE BEST MATERIALS AVAILABLE. OUR MISSION IS TO CONCEIVE TIMELESS DESIGNS TO IMPROVE THE QUALITY OF YOUR LIFE.”



**Snaidero Rino Spa**  
**Viale Rino Snaidero, 15 | 33030 Majano (Ud) | Italy**

SNAIDERO RINO SPA RESERVES THE RIGHT TO MAKE CHANGES AT ANY TIME IN THE INTEREST OF IMPROVING ITS PRODUCTS. IT IS PROHIBITED TO MAKE EVEN PARTIAL REPRODUCTIONS OF TEXTS, PICTURES OR DRAWINGS OF THE PRESENT CATALOG. ALL RIGHTS RESERVED. BRANDS AND LOGOS SHOWING ON THE PRESENT CATALOG ARE THE PROPERTY OF SNAIDERO RINO SPA AND OF THE COMPANIES THAT ARE DEPICTED RESPECTIVELY.

---

**[www.snaidero.com](http://www.snaidero.com)**

Direction & Graphic design:  
Marketing e Comunicazione Snaidero  
Printed in 2020

